

KOGANEI

SLIT TYPE RODLESS CYLINDER
ORV SERIES

**Space-saving
and Low-cost**



**Product range includes
bore sizes from
 ϕ 16 to ϕ 50**

**Now added to
the range**

- Equivalent to 20mm bore
- Equivalent to 32mm bore
- Equivalent to 50mm bore

SLIT TYPE RODLESS CYLINDER ORV SERIES

A New Wo

The ORV series is developed from
The ingenious own oval piston co

Low cost • Shorter

The standard price is about 50% lower than conventional slit-type rodless cylinders (compared with Koganei's own standard prices).

50% Standard price-reduction ratio (compared with Koganei product)

Achieves a shorter dead stroke than conventional slit-type rodless cylinder. It has reduced dead space by about 35% (Koganei product comparisons), to enable large space savings.

35% Dead stroke-reduction ratio (compared with Koganei product)

Actual dimensional comparisons of ORV 16×100 (in photograph) and ORCA 16×100 (in silhouette)

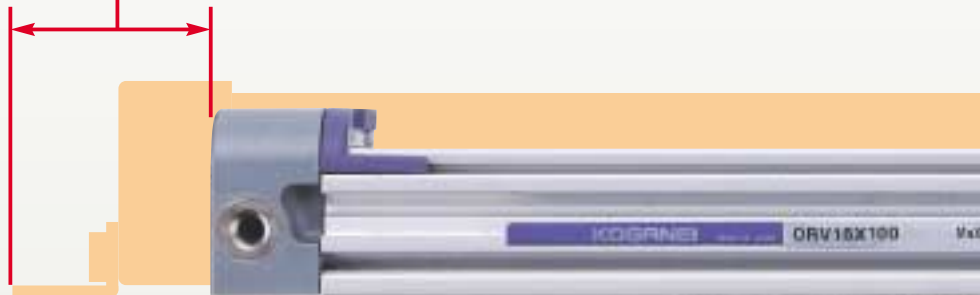

Lightweight Structure

The lightweight body of the slit-type rodless cylinder ORV series places no loads on either the actuator axis or the stand, even when using a Y-Z axis. Contributes to space savings and lighter weight for the overall devices.

High-strength Stainless Seal Tape

The original design stainless seal tape is the result of many years of experience. Achieves long life and low leakage compared with plastic seal tapes.

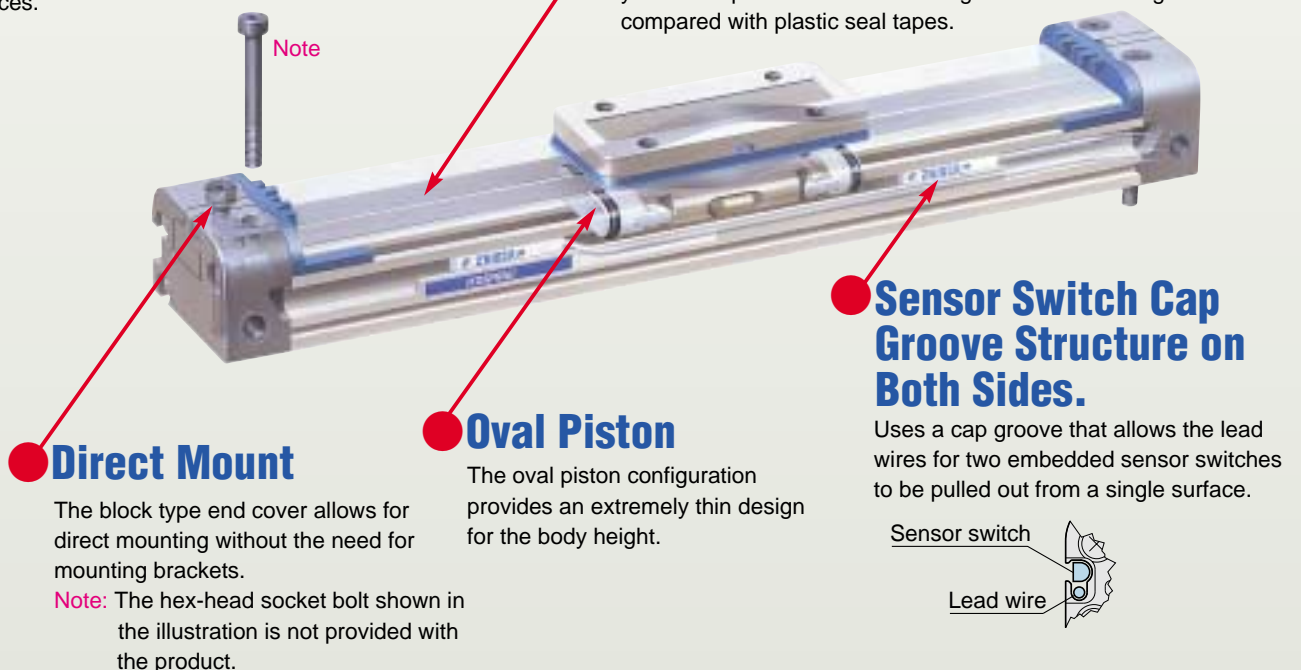

Direct Mount

The block type end cover allows for direct mounting without the need for mounting brackets.

Note: The hex-head socket bolt shown in the illustration is not provided with the product.

Oval Piston

The oval piston configuration provides an extremely thin design for the body height.

Sensor Switch Cap Groove Structure on Both Sides.

Uses a cap groove that allows the lead wires for two embedded sensor switches to be pulled out from a single surface.

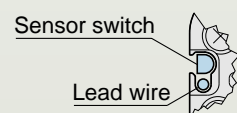

World Standard for Rodless Cylinders

From the concept of making slit-type rodless cylinders “low cost, shorter and thinner.”
 Configuration design opens up new rodless cylinder applications requiring a compact-working envelope area.

Thinner

About a 40% reduction in height (Koganei product comparison).
 The lower table compared to conventional rodless cylinders makes it possible for compact, simple equipment design.

Height-reduction ratio
 (compared with
 Koganei product)

40%

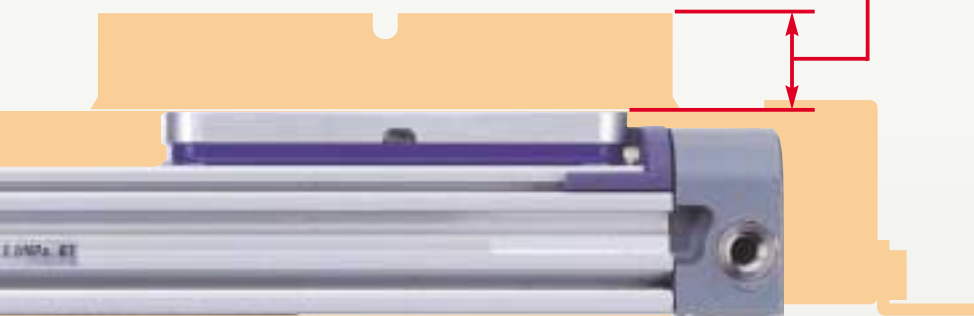

This rodless cylinder is the most compact even at the short 25mm strokes

Although conventional rodless cylinders were no more compact than regular air cylinders when the stroke was not very long, the slit-type rodless cylinder ORV series is more compact than regular cylinders even at 25mm strokes. And since it is a rodless cylinder, it is capable of non-rotating functions.

Best Matching with Linear Guides!

The slit-type rodless cylinder ORV series can be connected to linear guides with a M-type mount (option) that provides a low center of gravity, to achieve a slim form and smooth movement.

<Usage example>

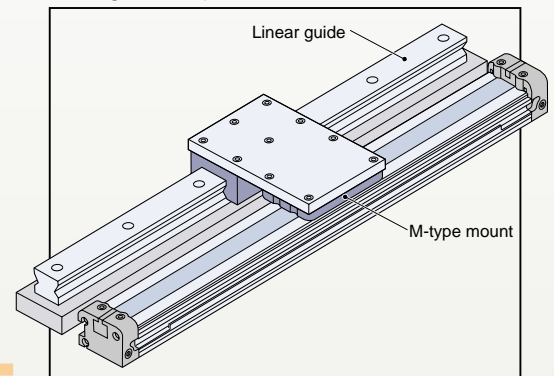

Caution

Before use, always read the “Safety Precautions” on page 3.

Standard Strokes Selection

The standard strokes range from the short 25mm to 1200mm. Up to 2000mm stroke maximum can be manufactured.

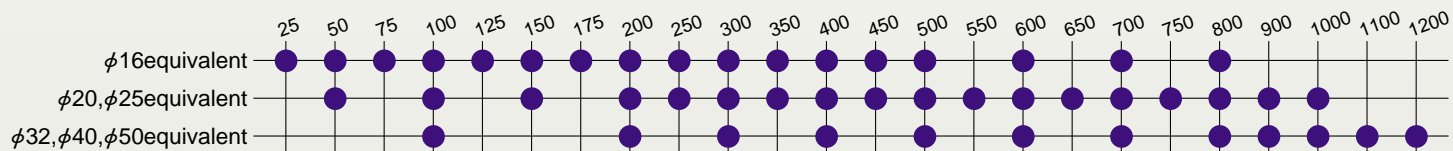

Remark: Strokes other than the standard stroke can be manufactured at 1mm pitch intervals.

Options provided to facilitate ease of use

- With shock absorber unit
- M-type mount
- F-type support



INDEX

Safety Precautions	3
Handling Instructions, and Precautions	7
Specifications List	12
Order Codes	14
Inner Construction and Names of Parts, and Materials	15
Dimensions	16
Sensor Switches	18





Safety Precautions (Slit type Rodless Cylinder ORV series)

Before selecting and using products, please read all the Safety Precautions carefully to ensure proper product use.

The Safety Precautions shown below are to help you use the product safely and correctly, and to prevent injury or damage to assets beforehand.

Follow the Safety Precautions for: ISO4414 (Pneumatic fluid power—Recommendations for the application of equipment to transmission and control systems), JIS B 8370 (Pneumatic system regulations)

The directions are ranked according to degree of potential danger or damage: “DANGER!” “WARNING!” “CAUTION!” and “ATTENTION!”

 DANGER	Expresses situations that can be clearly predicted as dangerous. If the noted danger is not avoided, it could result in death or serious injury. It could also result in damage or destruction of assets.
 WARNING	Expresses situations that, while not immediately dangerous, could become dangerous. If the noted danger is not avoided, it could result in death or serious injury. It could also result in damage or destruction of assets.
 CAUTION	Expresses situations that, while not immediately dangerous, could become dangerous. If the noted danger is not avoided, it could result in light or semi-serious injury. It could also result in damage or destruction of assets.
 ATTENTION	While there is little chance of injury, this content refers to points that should be observed for appropriate use of the product.

■ This product was designed and manufactured as parts for use in General Industrial Machinery.

- Before selecting the equipment and using any product, always read the Safety Precautions, the Catalog, the Instruction Manual, etc.
- After reading the Instruction Manual, etc., always place the Manual where it can be easily available for reference to users of this product.
- If transferring or lending the product to another person, always attach the Instruction Manual, etc., to the product where it is easily visible, to ensure that the new user can use the product safely and properly.
- The danger, warning, and caution items listed under these "Safety Precautions" do not cover all possible cases. Read the catalog and user's manual carefully, and always keep safety first.

DANGER

- Do not use for the purposes listed below:
 1. Medical equipment related to maintenance or management of human lives or bodies.
 2. Mechanical devices or equipment designed for the purpose of moving or transporting people.
 3. Critical safety components in mechanical devices.
This product has not been planned or designed for purposes that require advanced stages of safety. It could cause injury to human life.
- Do not use in locations with or near dangerous substances such as flammable or ignitable substances. This product is not explosion-proof. It could ignite or burst into flames.
- While the product is in operation, avoid touching it with your hands or otherwise approaching too close. In addition, do not make any adjustments to the interior or to attached mechanisms (removal, etc., of shock absorber, stroke adjustment mechanism, sensor switch mounting position, piping tubes, or sealing plugs) while in operation. The actuator can move suddenly, possibly resulting in injury.
- When attaching the product, always ensure that it is securely fixed in place. Dropping the product or improper operation could result in injury.
- Persons who use a pacemaker, etc., should keep a distance of at least one meter away from the product. There is the possibility that the pacemaker will malfunction due to the strong magnet built into the product.
- Never attempt to rebuild the product. It could result in abnormal operation leading to injury, electric shock, fire, etc.
- Never attempt inappropriate disassembly or assembly of the product's basic configurations, or of its performance or functions. It could result in injury, electric shock, fire, etc.
- Do not splash water on the product. Spraying it with water, washing it, or using it underwater could result in malfunction of the product leading to injury, electric shock, fire, etc.
- When operating the product, always install a speed controller, and gradually loosen the needle valve from a choked state to adjust the speed upward. Failure to make this adjustment could result in sudden blasts of air, putting lives at risk.

WARNING

- Do not use the actuator for equipment whose purpose is absorbing the shocks and vibrations of mechanical devices. It could break and possibly result in injury or in damage to mechanical devices.
- Before supplying air or electricity to the device and before starting operation, always conduct a safety check of the area of machine operation. Careless supply of air or electricity could possibly result in electric shocks, or in injury caused by contact with moving parts.
- Do not touch the terminal and the miscellaneous switches, etc., while it is plugged in. There is the possibility of electric shock and abnormal operation.
- Always refer to the Catalog to confirm that product wiring and piping is being conducted correctly. Improper wiring or piping could result in malfunctions.
- Do not allow the product to be thrown into fire. The product could explode and release toxic gases.
- Do not sit on the product, place your foot on it, or place other objects on it.
Accidents such as falling and tipping over could result in injury. Dropping the product may damage or break the product resulting in abnormal, improper or erratic operation.
- When conducting any kind of operation for the product, such as inspection, repair, installation/removal of piping, or replacement, always turn off the air supply completely and confirm that residual pressure inside the product or in piping connected to the product is zero before proceeding.
In particular, be aware that residual air will still be in the air compressor or air storage tank. The actuator could abruptly move if residual air pressure remains inside the piping, causing injury.
- Do not use this product out of its specifications. Such use could result in product breakdown, malfunction, or damage.
- Use within the recommended load and speed specifications.
Use out of those recommended ranges could result in damage to the shock absorber or cylinder, and lead to physical injury.

- Use safety circuits or system designs to prevent damage to machinery or injury to personnel when the machine shuts down due to emergency stop or electrical power failure.
- Install relief valves, etc., to ensure that the actuator does not exceed its rated pressure when such pressure is rising due to external forces on the actuator. Excessive pressure could lead to breakdown and damage.

CAUTION

- Do not use in locations under direct sunlight (ultraviolet), in locations subject to dust, salt, or iron powder, or in the media and/or the ambient atmospheres that include organic solvents, phosphoric ester-based hydraulic fluids, sulfur dioxide gas, chlorine gas and acids. These conditions could lead functional shutdowns, sudden degraded performance, or shortened operating life in a brief period of time. For the materials used, see Major Parts and Materials.
- When mounting the product, leave room for adequate working space around it. Failure to assure adequate working space will make it more difficult to conduct daily inspections or maintenance, which could eventually lead to system shutdown or damage to the product.
- When transporting or mounting heavy products (medium or large cylinders, etc.), use a lift or support tools for support, bring a number of workers to assist, etc., to assure that adequate measures are being taken for personal safety.
- Do not bring floppy disks and magnetic media, etc., within one meter of the product. There is the possibility that the data on the floppy disks will be destroyed due to the magnetism of the magnet.
- Do not scratch, dent, or deform the actuator by climbing on the product, using it as scaffold, or placing objects on top of it. It could result in damaged or broken products that result in operation shutdown or degraded performance.
- Do not use the sensor switch in locations subject to large electrical currents or powerful magnetic fields. It could result in erratic operation. In addition, do not use magnetized materials in attached materials. The magnetic force could leak, possibly resulting in erratic operation.
- Never use another company's sensor switch with these products. It could possibly cause error or accidental operation.
- When performing a mounting or adjustment work, put up "now working" signs to prevent unintentional inputs of air or electrical power, etc. Such accidental inputs may cause electrical shock, or sudden activation of the actuator that could result in physical injury.
- Reckless throwing away oil sealed inside the shock absorber pollutes the environment. Use prescribed waste oil disposal methods to dispose of the oil.
- If using a shock absorber, always use the KSHGV (additional parts). Use of any other shock absorbers could mean inadequate absorption of shocks and damage to the product.

ATTENTION

- When considering the possibility of using this product in situations or environments not specifically noted in the Catalog or Instruction Manual, or in applications where safety is an important requirement, such as in an airplane facility, near combustion equipment, near leisure equipment, near safety equipment and other places where human life or assets may be greatly affected, take adequate safety precautions such as application with enough margins or fail-safe measures for ratings and performance. Please consult KOGANEI with any questions.

- Use a protective cover, etc., to ensure that human bodies do not come into direct contact with the operating portions of mechanical devices, etc.
- Do not make the controls in a way that would cause work to fall down during power outages. Make the controls so that they prevent the table or work, etc., from falling during power outages or emergency stop of the mechanical devices.
- Always check the Catalog and other reference materials for product wiring and piping.
- When handling the product, wear protective gloves, safety glasses, safety boots, etc., to assure safety.
- When the product can no longer be used, or is no longer necessary, dispose of it appropriately as industrial waste.
- Pneumatic equipment can exhibit degraded performance and function over its operating life. Always conduct daily inspections of the pneumatic equipment, and confirm that all requisite system functions are satisfied, to prevent accidents from happening.
- For inquiries about the product, see your nearest Koganei sales office, or Koganei overseas division. The address and telephone number is shown on the back cover of this catalog.

OTHER

- Always observe the following items.
KOGANEI cannot be responsible if these items are not properly observed.
 1. When using this product in pneumatic systems, always use genuine KOGANEI parts or compatible parts (recommended parts).
When conducting maintenance and repairs, always use genuine KOGANEI parts or compatible parts (recommended parts). Always observe the required methods.
 2. Do not attempt inappropriate disassembly or assembly of the product's relating to basic configurations, or of its performance or functions.

Safety Precautions (Sensor Switch)



Design and Selection

1. Check the specifications.

As use of this equipment over the specified ranges of voltage, current, temperature, shock, etc., could result in breakdown or abnormal operation, always read the specifications carefully to ensure correct use.

2. Avoid mounting cylinders in close proximity.

Mounting two or more cylinders with sensor switches in close proximity could result in erroneous operation of the sensor switch, due to magnetic field interference with the system.

3. Be cautious about sensor switch ON time for positioning detection at intermediate stroke position.

Be aware that if the sensor switch is mounted at an intermediate position of the cylinder stroke for detection of piston travel, the sensor switch actuation time may be too short when the cylinder speed is very rapid so that the load (sequencer, etc.) may fail to activate.

Maximum cylinder speed for positioning detection

$$V[\text{mm/s}] = \frac{\text{Sensor switch actuation range [mm]}}{\text{Time required for activating load [ms]}} \times 1000$$

4. Keep wiring as short as possible.

In reed sensor switches, in particular, excessively long wiring (10m or more) can shorten the operating life of the sensor switch with capacitive surges. If the wiring must be lengthy, install protection circuits.

Use protection circuits for inductive or capacitive loads, as well.

5. Avoid repeated or excessive bending to lead wires, or pulling of lead wires.

Applying repeated bending stress or tension force on the lead wire could result in wire breaks.

6. Check for leak current.

Two-lead wire solid state sensor switches produce leak current to activate their internal circuits and leads flow even when turned off condition. Check if they satisfy the following formula.

Input off current of programmable controller > Leak current

If the above formula cannot be satisfied, select a three-lead wire solid state sensor switch, instead. Also note that parallel connection of a total of n sensor switches will lead to n times the leak current.



Caution

1. Check for sensor switch internal voltage drop.

Series connection of reed sensor switches with indicator lamps or two lead wire solid state sensor switches causes increasing internal voltage drop, and the load may fail to activate. A total of n sensor switches will lead to n times the internal voltage drop. Ensure that the system satisfies the following formula.

Supply voltage - Internal voltage drop $\times n$ > Minimum operating voltage for load

In relays with their rated voltage of less than DC24V, check to see whether the above formula is satisfied, even in the case of $n = 1$.

If the above formula cannot be satisfied, select either a reed sensor switch without indicator lamp, or a three lead wire solid state sensor switch.

2. Do not use with another company's cylinders.

The sensor switches are designed for use with Koganei cylinders. Use with other company's cylinders could lead to abnormal operation.

3. Absolutely do not use other company's sensor switches with Koganei products.

Such application could lead to abnormal or runaway operation.



Installation and Adjustment



Warning

1. Do not apply another magnetic fields to the sensor switches during cylinder operations.

Unintended operation could result in equipment breakdown or personal injury.



Caution

1. Install sensor switches in their center of the operating range.

Adjust the mounting position of a sensor switch so that the piston stops in the center of its operating range (the range where the sensor turns on). Operations can be unstable if mounted on the end of the operating range (at the boundary near ON and OFF). Also be aware that the operating range can vary with changes in temperature.

2. Maintain the tightening torque of sensor switches when mounting.

Over tightening beyond the fastening torque may damage the mounting screws, mounting bracket, sensor switches, etc. In addition, insufficient tightening torque could cause the sensor switch position to change, resulting in operating instability. For the tightening torques, see the summary of sensor switch adjustment on page 19.

3. Do not use sensor switch lead wires to lift a cylinder.

After mounting a sensor switch to a cylinder, do not grab the lead wires to lift the cylinder. Never do this, as it could result in lead wire disconnections, and could also apply stress to the interior of the sensor switch, resulting in breakage of internal elements.

4. Do not drop switches, or bump them against others.

Do not apply excessive shocks to switches (294.2m/s² {30G} or more) such as hitting, dropping, or bumping.

In reed sensor switches, the contact reed can be activated unintentionally and causing it to send sudden signals. It can also cause changes in the contact interval that lead to changes in sensor switch sensitivity and result in erratic operation. Even if the sensor switch case is undamaged, the inner parts of the sensor switch may suffer breakdowns or give erroneous operation.

5. Do not use sensor switches in places where large current or other magnetic fields are present.

This could lead to unintentional operation. Do not use magnetic material for the mounting bracket. Magnetic force could be reduced, resulting in erratic operation.



Wiring

Danger

1. Avoid letting moving objects near a sensor switch come into contact with it.

When cylinders with sensor switches move, or when moving objects are nearby, do not let the moving objects come into contact. In particular, lead wires could become worn out or damaged, inducing operating instability in the sensor switch. In the worst case, it could result in current leaks or electrical shocks.

2. Always turn off the power supply for wiring work.

Conducting wiring work while the power is on could result in electric shocks. Also, wiring errors could damage sensor switches in an instant. Turn on the power only after wiring work is complete.

Warning

1. Check with the catalog, etc., to ensure correct wiring work for sensor switches.

Wrong wiring will cause abnormal operations.

2. Do not share the same wiring with power or high voltage lines.

Avoid wiring in parallel to or shared with power or high voltage line. The sensor switch or control circuit may suffer electric noise that results in erratic operation.

3. Avoid bending the lead wire, or applying tension force to it.

Placing repeated bending stress or tension force on the lead wire could result in wire breaks.

4. Check polarity in the wiring.

In sensor switches that specify polarity (+, -, output), be sure wiring connections are correct. The wrong polarity could result in damage to the sensor switch.

Caution

1. Avoid short circuiting the loads.

Turning a sensor switch on while the load is short-circuited causes overcurrent which can damage the sensor switch in an instant.

Example of short circuit of load: Sensor switch's output lead wire is directly connected to the power supply.



General Precautions

Piping

1. Always thoroughly flush out (blow with compressed air) the piping before connecting it. Entering metal chips, sealing tape, rust, etc., generated during plumbing could cause air leaks or other malfunctions.

2. When screwing piping or fittings to rodless cylinders, tighten them using the following tightening torques.

Connecting thread	Tightening torque N·m(kgf·m)
M5×0.8	1.57 {0.16}
Rc1/8	6.86~8.83 {0.69~0.88}
Rc1/4	11.77~13.73 {1.18~1.37}
Rc3/8	21.57~23.54 {2.16~2.35}

Atmosphere

1. When using in locations subject to dripping water, dripping oil, or to large amounts of dust, either use a cover, etc., for protection, or mount with the piston yoke facing downward.

2. Do not conduct welding operations near the slit-type rodless cylinder **ORV** series. Welding sparks could damage the outer sealing tape, etc.

3. **ORV** cylinders can not be used when the media or ambient atmosphere contains the following substances: Organic solvents, phosphate ester-based oils, sulfuric acid gas, chlorine gas, acids.

Lubrication

This equipment can be used without lubricating oil. If lubrication is used, it must be turbine oil Class 1 (ISO VG32) or its equivalent.

Media

1. Use air for media. Consult with us for the use of any other media.

2. Air used for the slit-type rodless cylinder **ORV** series should be clean air that contains no deteriorated compressor oil, etc. Install an air filter (filtration of 40 μm or less) near the cylinder or valve to remove drain muck or dust. In addition, remove the drain in the air filter periodically.

Handling Instructions, and Precautions



Selection and Mounting

Maximum load and moment

While the slit-type rodless cylinder **ORV** series can be used while applying direct loads, do not let the load or moment exceed the values shown in the table below. In addition, since payload may vary depending on the speed, confirm the rubber bumper and shock absorber capabilities on page 8 before use.

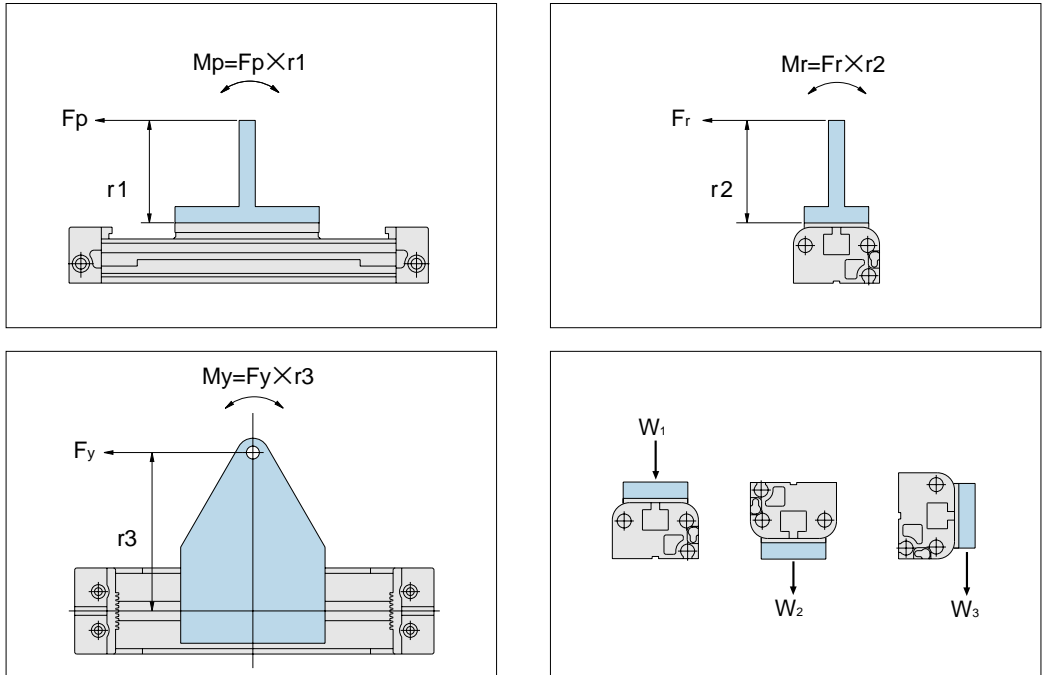

Pitching direction moment : $M_p = F_p \times r_1$ (N·m)
 Rolling direction moment : $M_r = F_r \times r_2$ (N·m)
 Yawing direction moment : $M_y = F_y \times r_3$ (N·m)
 Maximum payload : W_1, W_2, W_3 (N)

Model	Moment direction	M _p N·m {kgf·m}	M _r N·m {kgf·m}	M _y N·m {kgf·m}	Without shock absorber			With shock absorber		
					W ₁ N {kgf}	W ₂ N {kgf}	W ₃ N {kgf}	W ₁ N {kgf}	W ₂ N {kgf}	W ₃ N {kgf}
ORV16		3.2 {0.32}	0.5 {0.05}	0.5 {0.05}	20 {2.0}	20 {2.0}	20 {2.0}	40 {4.1}	40 {4.1}	20 {2.0}
ORV20		6.3 {0.63}	1.2 {0.12}	1.2 {0.12}	32 {3.3}	32 {3.3}	32 {3.3}	70 {7.1}	70 {7.1}	35 {3.5}
ORV25		12 {1.2}	1.6 {0.16}	1.6 {0.16}	50 {5.1}	50 {5.1}	50 {5.1}	120 {12.2}	120 {12.2}	60 {6.1}
ORV32		30 {3.0}	3.2 {0.32}	3.2 {0.32}	80 {8.2}	80 {8.2}	80 {8.2}	200 {20.4}	200 {20.4}	100 {10.2}
ORV40		60 {6.0}	6.3 {0.63}	6.3 {0.63}	120 {12.2}	120 {12.2}	120 {12.2}	300 {30.5}	300 {30.5}	150 {15.2}
ORV50		100 {10.0}	10 {1.0}	10 {1.0}	200 {20.4}	200 {20.4}	200 {20.4}	480 {48.9}	480 {48.9}	240 {24.5}

Caution: Do not let the moment, which includes inertial force generated during load movement or stopping, exceed the values shown in the table above.

Hold the mass and speed within the range of the rubber bumper and shock absorber capability curves.

Cushion capability

Rubber bumper capability

The slit-type rodless cylinder ORV series comes with rubber bumpers as standard equipment. The absorbable mass and impact speed, however, falls within the “without shock absorber” range shown in the “rubber bumper shock absorber performance curve” below. Do not use when the maximum impact speed exceeds 500mm/s.

Shock absorber capability

The slit-type rodless cylinder ORV series uses shock absorbers as optional equipment. The absorbable mass and impact speed, however, falls within the “with shock absorber” range shown in the “rubber bumper shock absorber performance curve” below. Do not use when the maximum impact speed exceeds 800mm/s.

Rubber bumper and shock absorber performance curve

(In horizontal use, at a pressure of 0.5MPa)

The “mass” in the graph refers to the mass conveyable by the ORV series. “Impact speed” refers to the speed immediately before striking the rubber bumper or shock absorber. Note that this is not the same as “average speed (cylinder stroke/time required).”

(See “Impact speed curve” at lower right.)

Without shock absorber

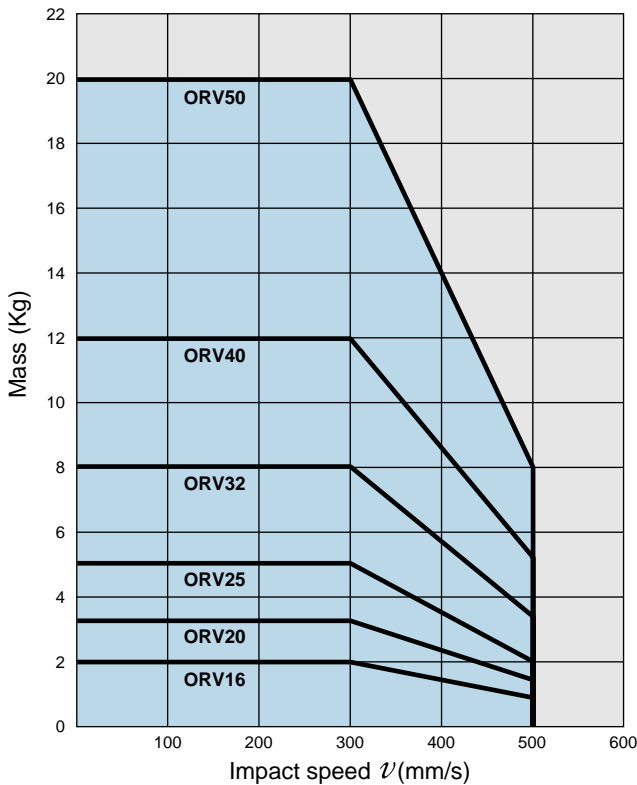

With shock absorber

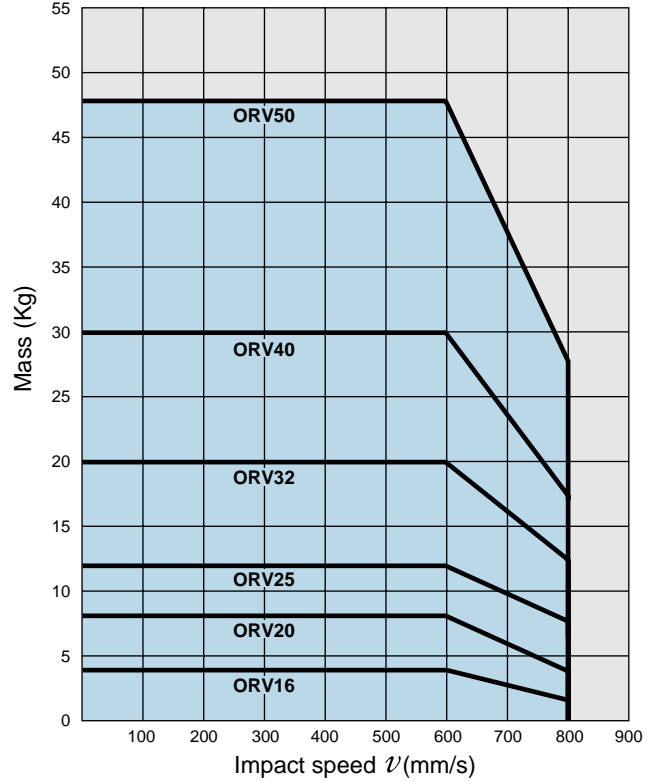

Impact speed curve (In horizontal use, at a pressure of 0.5MPa)

The graph below is a chart showing the impact time at 800mm/s and 500mm/s for each stroke of the table at stroke end.

For use, set the times on the upper side of the curve.

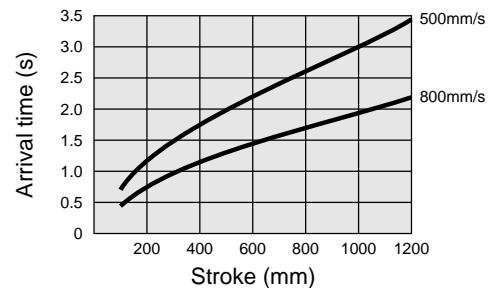

Amount of stroke change due to rubber bumper

In the slit-type rodless cylinder ORV series, note that use of the rubber bumper results in the stroke varying according to pressure as shown in the figure below. (The diagram below shows the displacement of the rubber bumper on one side.)

● ORV16 · 20

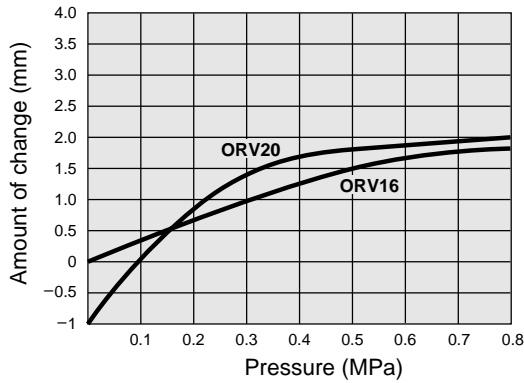

● ORV25 · 32

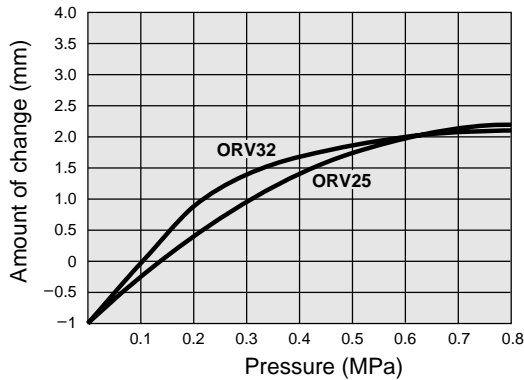

● ORV40 · 50

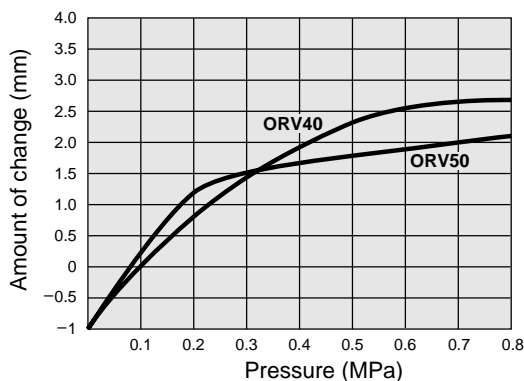

Caution: When using a rodless cylinder, select a suitable cushion and/or shock absorber to prevent rebounding. Rebound could result in such problems as breakage of the seal band.

Impact energy calculation

Horizontal impact

$$E = E_1 + E_2 = \frac{m \cdot v^2}{2} + F_o \cdot L$$

Vertical impact Note 1

When falling <small>Note 2</small>	When rising
$E = E_1 + E_2 + E_3 = \frac{m \cdot v^2}{2} + F_o \cdot L + m \cdot g \cdot L$	$E = E_1 + E_2 - E_3 = \frac{m \cdot v^2}{2} + F_o \cdot L - m \cdot g \cdot L$

Note 1: For eccentrically angled impacts, replace E3 with $E_3' = m \cdot g \cdot L \cdot \sin \theta$.

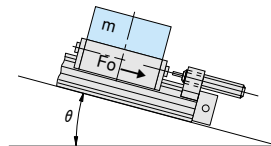

Note 2: A smaller pressure P when falling than rising can move a heavier load.

- E : Total energy at impact ... [J]
- E₁ : Kinetic energy ... $\frac{m \cdot v^2}{2}$
- E₂ : Additional energy of cylinder thrust ... $F_o \cdot L$ [J]
- E₃ : Additional energy of load ... $m \cdot g \cdot L$ [J]
- m : Mass [kg]
- v : Impact speed [m/s]
- g : Gravity acceleration 9.8 [m/s²]
- F_o : Cylinder thrust ... $= \frac{\pi}{4} \cdot D^2 \cdot P$ [N]
- [D: Cylinder inner diameter (mm) P: Air pressure (MPa)]
- L : Absorbance stroke of shock absorber [m]



Mounting

Mounting

1. While there are no particular restrictions on mounting direction in the slit-type rodless cylinder ORV series, mount the piston yoke so that it faces downward or protect with a cover, etc., when mounting in locations subject to dripping water or oil, etc., or to large amounts of dust.
2. Never engage in electric welding either during or after mounting the slit-type rodless cylinder ORV series. Flows of welding current to the cylinder could generate arcs that result in damage or depositions.
3. Be careful to avoid generating scratches or dents, etc., on the cylinder barrel.
4. If using in locations where the cylinder can easily become soiled, conduct cleaning at regular intervals. After cleaning, always apply grease to sliding section of the cylinder barrel and outer sealing tape surface.
5. Mount the cylinder barrel so that it cannot be twisted. Insufficient flatness of the mounting surface could result in cylinder barrel twisting, damaged tapes, air leaks, and operating malfunctions.

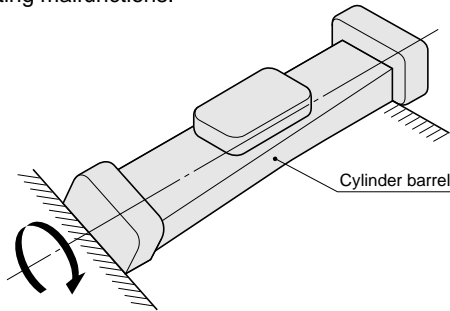

6. Precautions for the support types

Two-point support at both ends	Three-point support
※ For two-point support at both ends, and three-point support, always mount so that the cylinder barrel can take 10mm or more contact.	
Support on bottom surface of barrel	
When supported directly on the bottom surface of the barrel, as shown above, the load can be applied without mounting other supports.	

7. When the total cylinder length is long, the load could give a large deflexion that could result in operating malfunctions. If the relationship between the load on a two-point support at both ends and the stroke exceeds the range shown in the figure below, always use an intermediate F-type support.

● ORV16

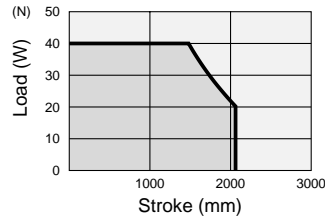

● ORV20

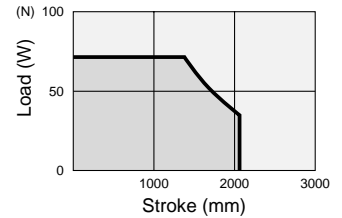

● ORV25

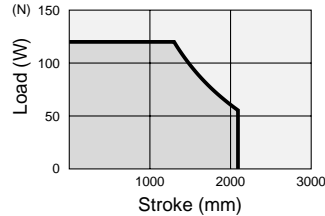

● ORV32

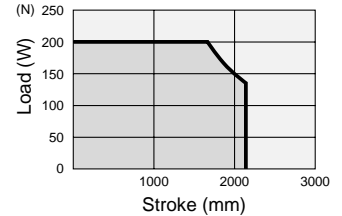

● ORV40

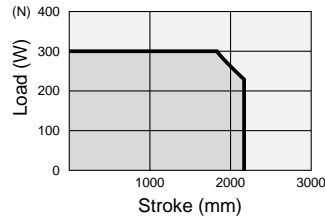

● ORV50

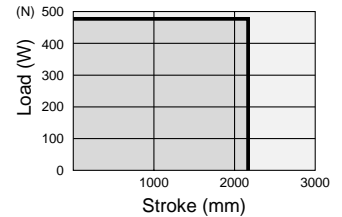

Mounting the shock absorber, and stroke adjustment

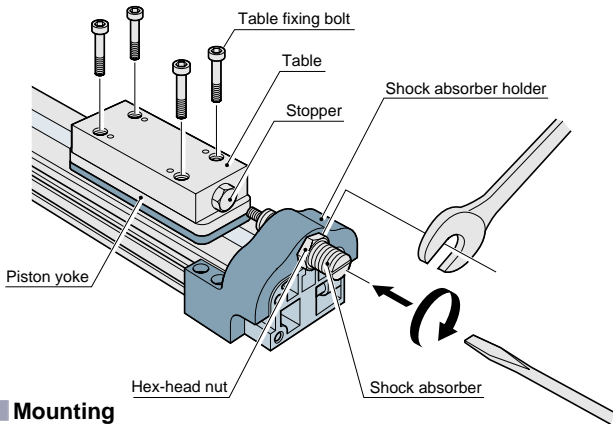

Mounting

1. There are no particular restrictions on mounting position so long as the end surface of the shock absorber holder does not protrude beyond the cylinder end surface. (Can also be used at an intermediate position.)
2. Mount so that the shock absorber and the stopper on the table side are completely in contact with the entire surface.
3. Use the shock absorber within the range of the shock absorber performance limits (the range of its performance curve).
4. Maximum impact speed of the shock absorber is 800mm/s. Note that this is not the same as the average speed. The speed at time of impact should not exceed 800mm/s.
5. Do not use the shock absorber in locations subject to dripping water or oil, or to large amounts of dust. If using in such locations, use a cover, etc., to prevent the unit from being directly subjected to dripping water, etc. It could result in operating malfunctions, or in reduced absorption energy.
6. Do not loosen the setscrew placed in the center of the shock absorber's back end surface. The oil charged inside the unit would leak out, and reducing shock absorber performance.
7. Do not mount shock absorbers not approved by us for use with this product. Because product characteristics vary between shock absorbers, the use of other shock absorbers could incur damage, etc., to the cylinder.
8. Use the provided table fixing bolt to fix the table to the piston yoke.

Mounting bolt tightening torques

Model	Tightening torque N-cm {kgf-cm}	Mounting bolt
ORV16	2.0{0.2}	M4×0.7
ORV20	2.0{0.2}	M4×0.7
ORV25	4.0{0.4}	M5×0.8
ORV32	7.0{0.7}	M6×1
ORV40	7.0{0.7}	M6×1
ORV50	15.0{1.5}	M8×1.25

Remark: Tighten the table fixing bolt as a guide with the above values.

Shock absorber position adjustment

- ① Loosen the hex-head nut holding the shock absorber.
- ② Use a screwdriver to rotate the shock absorber and adjust its position.
- ③ When the desired position has been reached, tighten the hex-head nut to fix in place.

Hex-head nut tightening torque

Model	Tightening torque N-cm {kgf-cm}	Width across flats mm
ORV16	8.0{0.8}	13
ORV20	8.0{0.8}	14
ORV25	10.0{1.0}	17
ORV32	24.0{2.4}	21
ORV40	30.0{3.0}	24
ORV50	78.0{7.8}	27

Mounting a workpiece

1. When using the piston yoke to mount a workpiece, mount within the tightening torques shown in the table below.

Mounting bolt tightening torques

Model	Tightening torque N-cm {kgf-cm}	Mounting bolt
ORV16	2.0{0.2}	M4×0.7
ORV20	2.0{0.2}	M4×0.7
ORV25	4.0{0.4}	M5×0.8
ORV32	7.0{0.7}	M6×1
ORV40	7.0{0.7}	M6×1
ORV50	15.0{1.5}	M8×1.25

2. Pay attention to the length of the mounting bolt threads. Screwing a bolt deeper than the thread hole depth could result in its bumping against the shim and tape guide, causing operation malfunctions.

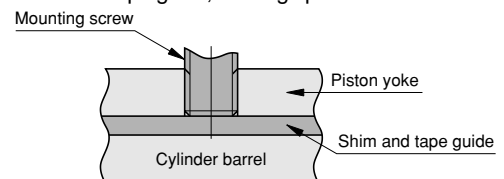

Mounting the F-type support

For the F-type support, use mounting holes in four places to fix in place with bolts.

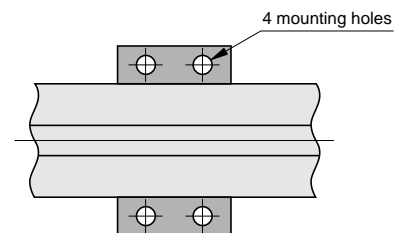

The bumpers

The cylinder is equipped with two types of bumpers, a mount bumper and a piston bumper. Cylinder stopping shocks are designed to be absorbed by the piston bumper, while the mount bumpers are auxiliary. The mount bumper should be removed when using M-type mounts, etc.

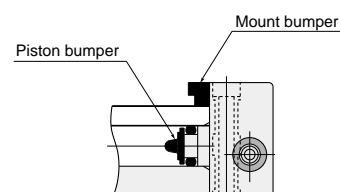

M-type mounts

Be sure to remove the mount bumper when using M-type mounts. If the mount bumper is left in place, the piston bumper will not function, which could drastically shorten the cylinder's operating life.

Slit-Type Rodless Cylinder ORV SERIES

Specifications List



Symbol

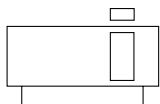

Specifications

Item	Model	ORV16	ORV20	ORV25	ORV32	ORV40	ORV50	
Bore size equivalent	mm	16	20	25	32	40	50	
Media		Air ^{Note 1}						
Operating type		Double-acting						
Operating pressure range	MPa {kgf/cm ² }	0.15~0.8 {1.5~8.2}						
Proof pressure	MPa {kgf/cm ² }	1.2 {12}						
Operating temperature range	°C	0~60						
Operating speed range	mm/s	Rubber bumper 80~500, with shock absorber 80~800 ^{Note 2}						
Cushion	Standard	With rubber bumper						
	Option	Shock absorber						
Lubrication		None						
Stroke adjustment range	mm	With shock absorber One side 0~-20				One side 0~-30		
Maximum stroke	mm	2000						
Stroke tolerance	mm	Stroke 2000mm or less	+5 ^{Note 3}	+6 ^{Note 3}	+6 ^{Note 3}	+6 ^{Note 3}	+7 ^{Note 3}	+6 ^{Note 3}
			+1	+1	0	+1	+1	+2
Port size		M5×0.8	Rc1/8	Rc1/8	Rc1/4	Rc1/4	Rc3/8	

Notes 1: Use clean air as a medium to remove water, dust, and oxidized oil.

2: Use the cushion capability, etc., on page 8 to select the speed.

3: Since the stroke will vary depending on the air pressure, see the graph on page 9 showing the stroke change due to rubber bumper.

Shock Absorber Specifications

Item	Model	ORV16	ORV20	ORV25	ORV32	ORV40	ORV50
Applicable shock absorber		KSHGV 10×10	KSHGV 12×10	KSHGV 14×12	KSHGV 18×15	KSHGV 20×16	KSHGV 22×25
Maximum absorption	J {kgf·m}	3 {0.3}	6 {0.6}	8 {0.8}	20 {2.0}	25 {2.5}	50 {5.0}
Absorbing stroke	mm	10		12	15	16	25
Maximum impact speed	mm/s	800					
Maximum operating frequency	cycle/min	30					
Spring return force	N {kgf}	4.9 {0.5}	8.7 {0.89}	8.8 {0.9}	14.5 {1.47}	18.1 {1.85}	25.2 {2.57}
Angle variation		2.5° or less					
Temperature range	°C	0~60					

Note: Depending on conditions of use, durability may vary from the slit-type rodless cylinder .

Theoretical Thrust

Model	Pressure area mm ²	Air pressure MPa						
		0.2	0.3	0.4	0.5	0.6	0.7	0.8
ORV16	201	40	60	80	101	121	141	161
ORV20	314	63	94	126	157	188	220	251
ORV25	490	98	147	197	245	294	343	392
ORV32	804	161	241	322	402	482	563	643
ORV40	1256	251	377	502	628	754	879	1005
ORV50	1963	393	589	785	982	1178	1374	1570

Bore Size Equivalent, and Stroke

		mm
Bore size equivalent	Standard stroke	Maximum manufacturable stroke
16	25,50,75,100,125,150,175,200,250,300,350,400,450,500,600,700,800	2000
20, 25	50,100,150,200,250,300,350,400,450,500,550,600,650,700,750,800,850,900,1000	
32, 40, 50	100,200,300,400,500,600,700,800,900,1000,1100,1200	

Remark: Non-standard strokes can be manufactured at 1mm intervals. For strokes beyond the maximum manufacturable stroke, or for non-standard strokes, ask the nearest Koganei office. Consult us for delivery.

Mass

Model	Zero stroke mass	Additional mass for each 25mm stroke	F-type support	M-type support	Shock absorber unit			Additional mass of sensor switch ^{Note 1}	
					Table	One side	Both sides	ZE□□□A	ZE□□□B
ORV16	0.20	0.03	0.008	0.019	0.077	0.062	0.124	0.015	0.035
ORV20	0.34	0.04	0.016	0.03	0.14	0.105	0.21		
ORV25	0.51	0.05	0.028	0.038	0.20	0.18	0.36		
ORV32	1.15	0.085	0.036	0.095	0.47	0.31	0.62		
ORV40	1.90	0.125	0.062	0.13	0.68	0.48	0.96		
ORV50	3.48	0.19	0.062	0.23	1.07	0.75	1.56		

Note 1: Sensor switch types A and B show the lead wire length.
A: 1000mm B: 3000mm

Air Flow and Air Consumption

While the slit-type rodless cylinder ORV series' air flow and air consumption can be found through the following calculation, the quick reference chart below provides the answers more conveniently.

$$\text{Air flow : } Q_1 = \frac{\pi D^2}{4} \times L \times \frac{60}{t} \times \frac{P+0.101}{0.101} \times 10^{-6} + 1^{**}$$

$$\text{Air consumption : } Q_2 = \frac{\pi D^2}{4} \times L \times 2 \times n \times \frac{P+0.101}{0.101} \times 10^{-6} + 1^{**}$$

Q₁: Air flow requirement for cylinder ℓ/min (ANR)
 Q₂: Air consumption of cylinder ℓ/min (ANR)
 D: Bore size equivalent mm
 L: Cylinder stroke mm
 t: Time required for cylinder to make one stroke s
 n: No. of cylinder reciprocations per minute times/min
 p: Air pressure MPa
 **: Air leakage volume from the slit area of the slit-type rodless cylinder (1 ℓ/min (ANR))
 cm³/reciprocation (ANR)

Equivalent bore size mm	Air pressure MPa						
	0.2	0.3	0.4	0.5	0.6	0.7	0.8
16	1.198	1.596	1.993	2.391	2.789	3.187	3.585
20	1.871	2.493	3.115	3.737	4.358	4.980	5.602
25	2.924	3.896	4.867	5.838	6.810	7.781	8.753
32	4.791	6.382	7.974	9.566	11.16	12.75	14.34
40	7.486	9.973	12.46	14.95	17.43	19.92	22.41
50	11.70	15.58	19.47	23.35	27.24	31.13	35.01

The figures in the table are for calculating the air flow and air consumption during one reciprocation of a rodless cylinder with stroke of 1mm. The actual air flow and consumption required can be found through the following method.

● Finding the air flow (for selecting F.R.L., valves, etc.)

Example 1. When operating a slit-type rodless cylinder ORV series with an equivalent bore size of 40mm at a speed of 300mm/s and under air pressure of 0.5MPa

$$14.95 \times \frac{1}{2} \times 300 \times 10^{-3} = 2.24 \text{ ℓ/s (ANR)}$$

$$\text{(At this time, the flow per minute becomes } 14.95 \times \frac{1}{2} \times 300 \times 60 \times 10^{-3} = 134.55 \text{ ℓ/min (ANR))}$$

● Finding the air consumption

Example 1. When operating a slit-type rodless cylinder ORV series with an equivalent bore size of 40mm and a stroke of 100mm, and under air pressure of 0.5MPa, for 1 reciprocation

$$14.95 \times 100 \times 10^{-3} = 1.495 \text{ ℓ/reciprocation (ANR)}$$

Example 2. When operating a slit-type rodless cylinder ORV series with an equivalent bore size of 40mm and a stroke of 100mm, and under air pressure of 0.5MPa, for 10 reciprocations per minute

$$14.95 \times 100 \times 10 \times 10^{-3} = 14.95 \text{ ℓ/min (ANR)}$$

Note: To find the actual air consumption required when using the slit-type rodless cylinder ORV series, add the air consumption of the piping to the air consumption obtained from the above calculation.

Order Codes

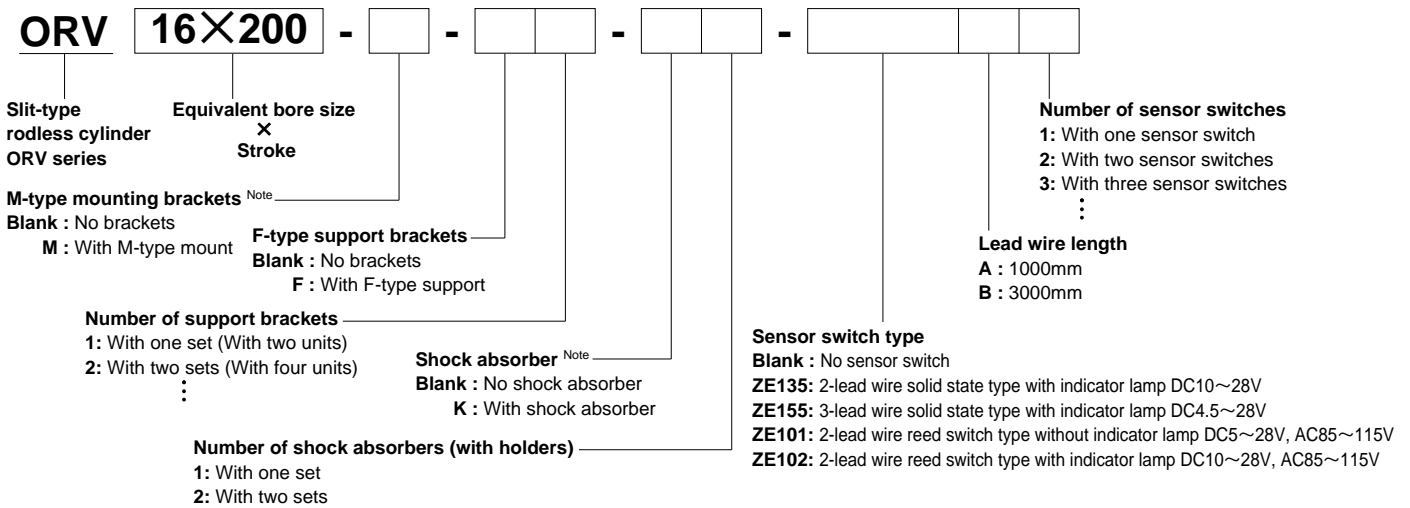

Additional Parts

● Shock absorber unit

(With shock absorber, table, and holder)

K-ORV



Equivalent bore size

16 : For ORV16, 20 : For ORV20
25 : For ORV25, 32 : For ORV32
40 : For ORV40, 50 : For ORV50

● M-type mounting brackets

M-ORV



Equivalent bore size

16 : For ORV16, 20 : For ORV20
25 : For ORV25, 32 : For ORV32
40 : For ORV40, 50 : For ORV50

● F-type support brackets (With two units)

F-ORV



Equivalent bore size

16 : For ORV16, 20 : For ORV20
25 : For ORV25, 32 : For ORV32
40 : For ORV40, 50 : For ORV50

● Shock absorber

KSHGV

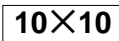

Mounting thread size × Stroke

10×10 — For ORV16
12×10 — For ORV20
14×12 — For ORV25
18×15 — For ORV32
20×16 — For ORV40
22×25 — For ORV50

Multi-orifice fixed type shock absorber

● Shock absorber holder

C-ORV



Equivalent bore size

16 : For ORV16, 20 : For ORV20
25 : For ORV25, 32 : For ORV32
40 : For ORV40, 50 : For ORV50

● Shock absorber table (With bolt)

T-ORV



Equivalent bore size

16 : For ORV16, 20 : For ORV20
25 : For ORV25, 32 : For ORV32
40 : For ORV40, 50 : For ORV50

● For the sensor switches, see page 18.

Repair Kit

● Seal kit Note

MK1-ORV



Equivalent bore size

16 : For ORV16, 20 : For ORV20
25 : For ORV25, 32 : For ORV32
40 : For ORV40, 50 : For ORV50

● Sealing tape kit

MK2-ORV



Equivalent bore size × Stroke

16 : For ORV16, 20 : For ORV20
25 : For ORV25, 32 : For ORV32
40 : For ORV40, 50 : For ORV50

● End cap assembly, R side

MK3-ORV



Equivalent bore size

16 : For ORV16, 20 : For ORV20
25 : For ORV25, 32 : For ORV32
40 : For ORV40, 50 : For ORV50

Note: The fewest order unit of the seal kit is every five sets.

● End cap assembly, L side

MK4-ORV



Equivalent bore size

16 : For ORV16, 20 : For ORV20
25 : For ORV25, 32 : For ORV32
40 : For ORV40, 50 : For ORV50

● Piston assembly

MK5-ORV



Equivalent bore size

16 : For ORV16, 20 : For ORV20
25 : For ORV25, 32 : For ORV32
40 : For ORV40, 50 : For ORV50

Dimensions (Unit mm)

● ORV Equivalent cylinder bore × Stroke

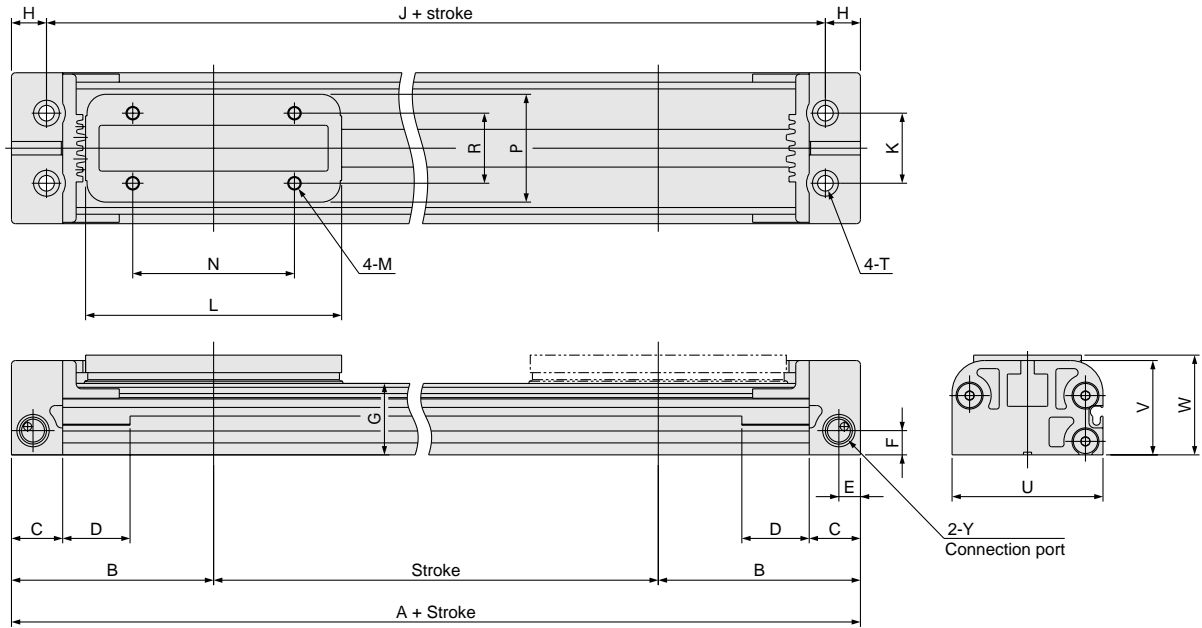

Note: For M-type mounts and F-type supports, see page 16.

Model Code	A	B	C	D	E	F	G	H	J	K	L
ORV16	112	56	15	25	5.5	9	20.5	11	90	18	67
ORV20	136	68	17	25	8	8.5	23	12	112	22	85
ORV25	152	76	19	25	8	9	26.5	13	126	26	95
ORV32	206	103	24	25	11.5	13	35	17	172	32	136
ORV40	242	121	26	25	11.5	18	43	19	204	36	165
ORV50	276	138	31	25	14	23	53	22	232	44	184

Model Code	N	M	P	R	T	U	V	W	Y
ORV16	40	M4×0.7 Depth 6	30	20	φ 3.6 φ 6.5 Counterbore depth 3.3	40	26	28	M5×0.8
ORV20	50	M4×0.7 Depth 7	35	24	φ 4.8 φ 8 Counterbore depth 4.5	48	30	32	Rc1/8
ORV25	60	M5×0.8 Depth 9	40	26	φ 5.8 φ 9.5 Counterbore depth 5.5	56	35	37	Rc1/8
ORV32	80	M6×1 Depth 11	50	32	φ 7 φ 11 Counterbore depth 6.5	70	46	48	Rc1/4
ORV40	100	M6×1 Depth 12	60	40	φ 7 φ 11 Counterbore depth 6.5	84	54	58	Rc1/4
ORV50	120	M8×1.25 Depth 16	70	48	φ 9 φ 14 Counterbore depth 8.5	102	68	72	Rc3/8

Optional Dimensions (Unit mm)

● M-type mount (M-ORV□)

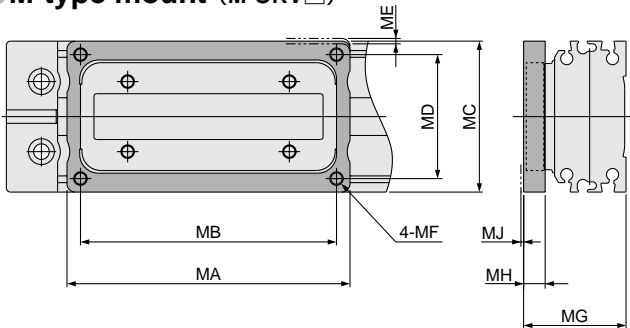

Note: Always remove the mount bumper when using M-type mounts.

M-type mount

Model Code	MA	MB	MC	MD	ME	MF	MG	MH	MJ
ORV16	75	66	46	38	2	M4×0.7 Depth 6	29	6	1
ORV20	94	85	51	42	2	M4×0.7 Depth 7	33	7	1
ORV25	105	95	56	46	2	M5×0.8 Depth 8	38	8	1
ORV32	150	138	70	58	3	M6×1 Depth 11	49	11	1
ORV40	181	166	80	68	3	M6×1 Depth 12	59	12	2
ORV50	205	188	94	78	3	M8×1.25 Depth 15	73	15	2

● F-type support (F-ORV□)

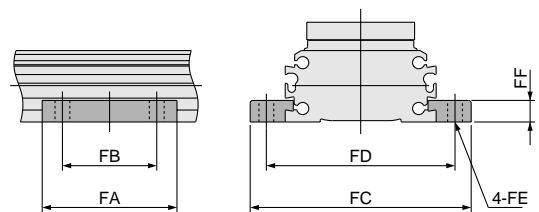

F-type support

Model Code	FA	FB	FC	FD	FE	FF
ORV16	40	28	54	47	φ 3.4	5
ORV20	50	35	66	57	φ 4.5	6.3
ORV25	50	35	82	70	φ 5.5	8
ORV32	65	45	96	84	φ 6.6	8
ORV40	75	55	116	100	φ 9	10
ORV50	75	55	134	118	φ 9	10

Optional Dimensions (Unit mm)

● With shock absorber

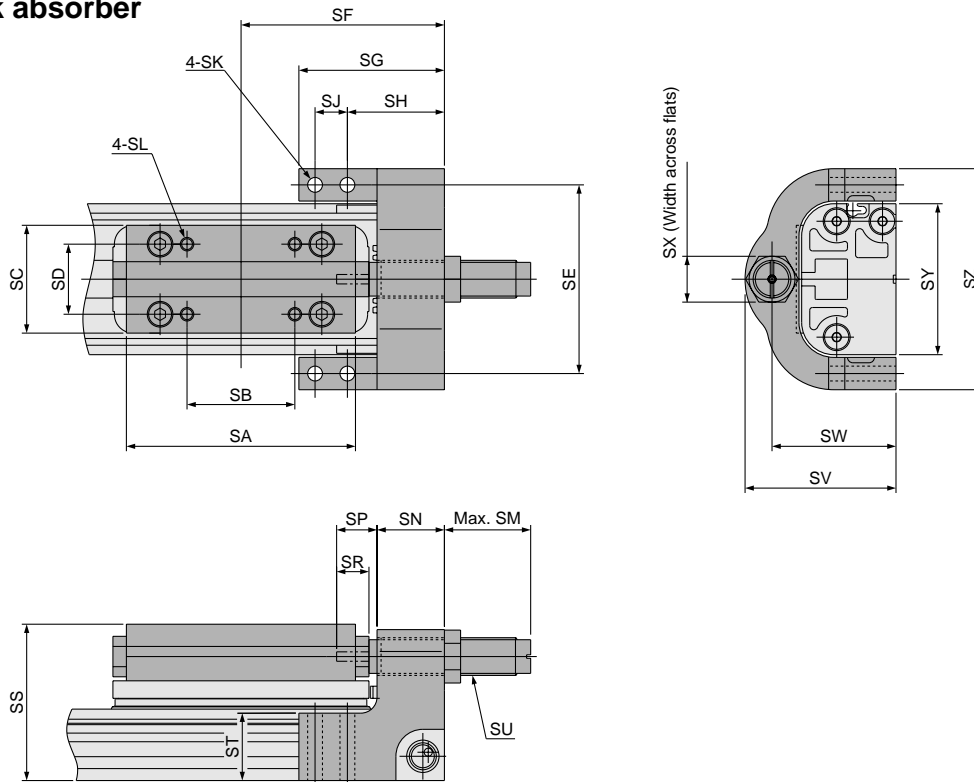

Note: For M-type mounts and F-type supports, see page 16.

Model	Code	SA	SB	SC	SD	SE	SF	SG	SH	SJ	SK	SL
ORV16		60	25	30	20	48	56	42	30	8	φ 3.4	M4×0.7 Depth 12
ORV20		78	30	35	24	57	68	48	35	8	φ 4.5	M4×0.7 Depth 12
ORV25		85	40	40	26	70	76	54	36	12	φ 5.5 φ 9.5 Counterbore depth 5.5	M5×0.8 Depth 14
ORV32		123	55	50	32	84	103	68	46	14	φ 6.6	M6×1 Depth 16
ORV40		150	75	60	40	100	121	74	48	18	φ 6.6 φ 11 Counterbore depth 6.5	M6×1 Depth 16
ORV50		167	88	70	48	118	138	90	62	17	φ 9	M8×1.25 Depth 18

Model	Code	SM	SN	SP	SR	SS	ST	SU	SV	SW	SX	SY	SZ
ORV16		27.5	20	12.5	10	44	16	M10×1	42	34.5	13	40	54
ORV20		30.5	22.5	13	10	50	18.5	M12×1	48	39.5	14	48	66
ORV25		31.5	25	15.5	12	58	25	M14×1.5	56	46	17	56	82
ORV32		35	31.5	18.5	15	74	28	M18×1.5	72	59.5	21	70	96
ORV40		38.5	35	19.5	16	85	40	M20×1.5	83	69	24	84	116
ORV50		54	42.5	28.5	25	103	44	M22×1.5	101	85	27	102	134

Shock Absorber Dimensions (Unit mm)

● KSHGV Mounting thread size × Stroke

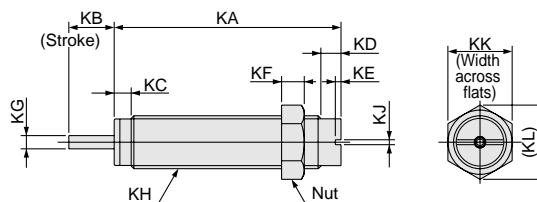

Model	Code	KA	KB	KC	KD	KE	KF	KG	KH	KJ	KK	KL
KSHGV10×10 (For ORV16)		50	10	3.5	5.5	1.5	3	φ 3	M10×1	1.3	13	14.2
KSHGV12×10 (For ORV20)		56	10	3.5	5.5	1.5	4	φ 3.5	M12×1	1.3	14	16.2
KSHGV14×12 (For ORV25)		60	12	4.5	5.5	1.5	6	φ 3.5	M14×1.5	1.3	17	19.6
KSHGV18×15 (For ORV32)		70	15	4.5	5.5	1.5	8	φ 5	M18×1.5	1.3	21	24.3
KSHGV20×16 (For ORV40)		77	16	4.5	5.5	1.5	8	φ 6	M20×1.5	1.3	24	27.5
KSHGV22×25 (For ORV50)		100	25	4.5	5.5	1.5	9	φ 6	M22×1.5	1.3	27	31.2

Sensor Switch

Solid State Type and Reed Switch Type

Symbol

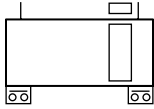

Specifications

● Solid state type

Item	Model	ZE135	ZE155
Wiring method		2-lead wire type	3-lead wire type
Direction of lead wire		Horizontal	
Power source voltage		—	DC4.5~28V
Load voltage		DC10~28V	DC4.5~28V
Load current		4~20mA (At 25°C, 10mA at 60°C)	50mA MAX.
Consumption current		—	10mA MAX. (DC24V)
Internal voltage drop ^{Note 1}		4.5V MAX.	0.5V MAX. (At 20mA with voltage of 10V or less)
Leakage current		1mA MAX. (DC24V, 25°C)	50 A MAX. (DC24V)
Response time		1ms MAX.	
Insulation resistance		100M% MIN. (At DC500V megas, between case and lead wire terminals)	
Dielectric strength		AC500V (50/60Hz) in one minute (Between case and lead wire terminals)	
Shock resistance ^{Note 2}		294.2m/s ² {30.0G} (Non-repeated)	
Vibration resistance ^{Note 2}		Total amplitude 1.5mm · 10~55Hz {88.3m/s ² (9.0G)}	
Protective structure		IEC IP67, JIS C0920 (Immersion proof type)	
Operating indicator		Red LED indicator lamp when ON	
Lead wire		PCCV0.2SQ×2 leads (Brown, blue)× ℓ ^{Note 3}	PCCV0.15SQ×3 leads (Brown, blue, black)× ℓ ^{Note 3}
Ambient temperature		0~60°C	
Storage temperature range		-10~70°C	
Mass		15g (For lead wire length A: 1000mm), 35g (For lead wire length B: 3000mm)	

Notes 1: Internal voltage drop will vary according to the load current.

2: According to Koganei test standards

3: Lead wire length ℓ : A ; 1000mm, B ; 3000mm

● Reed switch type

Item	Model	ZE101	ZE102
Wiring method		2-lead wire type	
Direction of lead wire		Horizontal	
Load voltage		DC5~28V	DC10~28V
Load current		40mA MAX.	5~40mA
Internal voltage drop ^{Note 1}		0.1V MAX (At load current of DC40mA)	3.0V MAX.
Leakage current		0mA	
Response time		1ms MAX.	
Insulation resistance		100M% MIN. (At DC500V megas, between case and lead wire terminals)	
Dielectric strength		AC1500V (50/60Hz) in one minute (Between case and lead wire terminals)	
Shock resistance ^{Note 2}		294.2m/s ² {30.0G} (Non-repeated)	
Vibration resistance ^{Note 2}		Total amplitude 1.5mm · 10~55Hz {88.3m/s ² (9.0G), Resonant frequency 2750 ± 250Hz	
Protective structure		IEC IP67, JIS C0920 (Immersion proof type)	
Operating indicator		None	Red LED indicator lamp when ON
Lead wire		PCCV0.2SQ×2 leads (Brown, blue)× ℓ ^{Note 3}	
Ambient temperature		0~60°C	
Storage temperature range		-10~70°C	
Contact protection measures		Required (See contact protection measures on page 20)	
Mass		15g (For lead wire length A: 1000mm), 35g (For lead wire length B: 3000mm)	

Notes 1: Internal voltage drop will vary according to the load current.

2: According to Koganei test standards

3: Lead wire length ℓ : A ; 1000mm, B ; 3000mm

Order Code

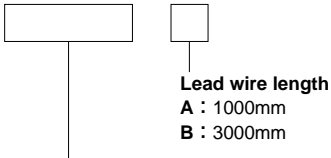

Sensor switch model

ZE135 : Solid state type	With indicator lamp	DC10V~28V	Horizontal lead wire	ZE155 : Solid state type	With indicator lamp	DC4.5V~28V	Horizontal lead wire
ZE101 : Reed switch type	Without indicator lamp	DC5V~28V	Horizontal lead wire	ZE102 : Reed switch type	With indicator lamp	DC10V~28V	Horizontal lead wire
		AC85~115V				AC85~115V	

Internal Circuit Diagram

● Solid state type

● 2-lead wire type (ZE135)

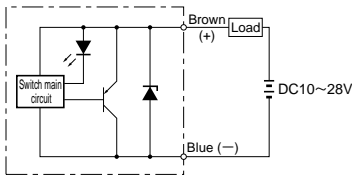

● 3-lead wire type (ZE155)

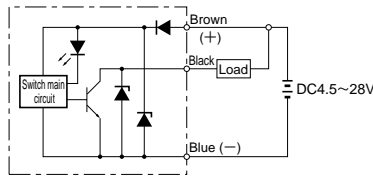

● Reed switch type

● Without indicator lamp (ZE101)

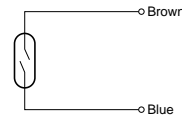

● With indicator lamp (ZE102)

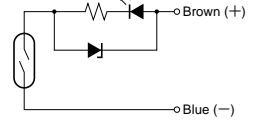

Sensor Switch Dimensions

(Unit mm)

● Horizontal lead wire

● With indicator lamp (ZE135, ZE155, ZE102)

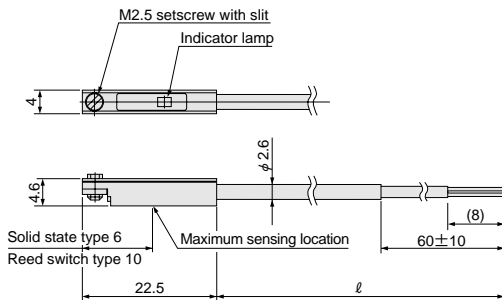

● Without indicator lamp (ZE101)

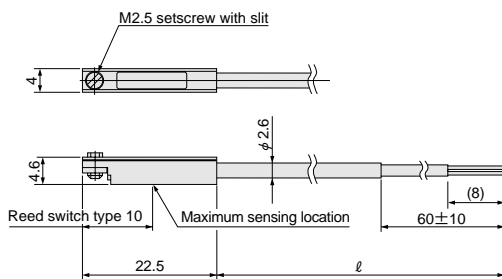

Instructions for Sensor Switch Movement

Loosening the sensor switch setscrew allows the sensor switch to be moved along the switch mounting groove on the barrel. In addition, the lead wires can be inserted into the groove of the end cap.

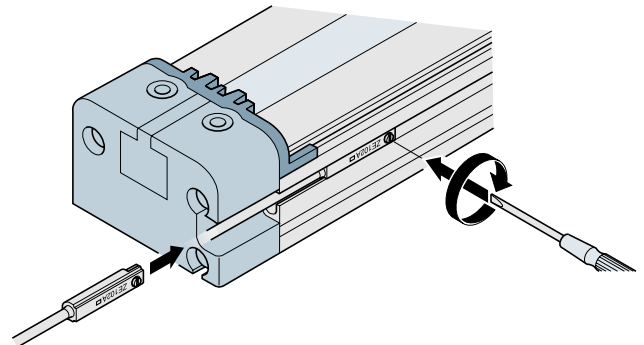

- Tightening torque for the setscrew is 20N·cm~30N·cm {2kgf·cm~3kgf·cm}.

Mounting Position for the End of Stroke Detection Sensor Switch

When the sensor switch is mounted in the position shown in the figure, the magnet reaches the sensor's maximum sensitivity position at the end of stroke.

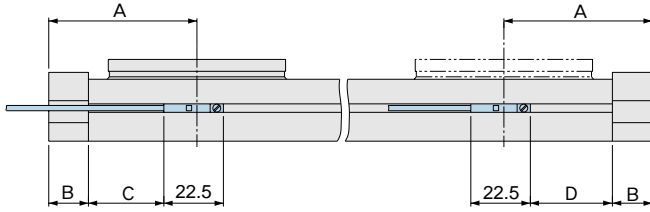

● Reed switch type (ZE101, ZE102) mm

Model	A	B	C	D
ORV16	56	15	28.5	31
ORV20	68	17	38.5	41
ORV25	76	19	44.5	47
ORV32	103	24	66.5	69
ORV40	121	26	82.5	85
ORV50	138	31	94.5	97

● Solid state type (ZE135, ZE155) mm

Model	A	B	C	D
ORV16	56	15	24.5	35
ORV20	68	17	34.5	45
ORV25	76	19	40.5	51
ORV32	103	24	62.5	73
ORV40	121	26	78.5	89
ORV50	138	31	90.5	101

Contact protection measures for the reed type sensor switch

To ensure stable use of the reed type sensor switch, implement the following contact protection measures.

● When connecting induction loads (Solenoid relays, etc.)

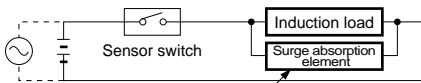

For DC.....Diode or CR, etc.
For AC.....CR, etc.

Diode: For forward direction, use circuit current or higher,
and for reverse direction, use reverse proof voltage
10 times or more of the circuit voltage

C : 0.01~0.1 F
R : 1~4kΩ

● When capacity surges are generated

(when lead wire length exceeds 10m)

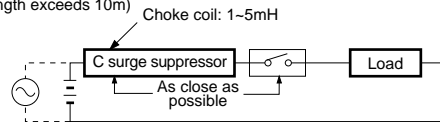

When Mounting Sensor Switches in Close Proximity

When mounting a sensor switch in close proximity to the ORV series, mount so that the distance between it and the cylinder does not fall below the values in the table below.

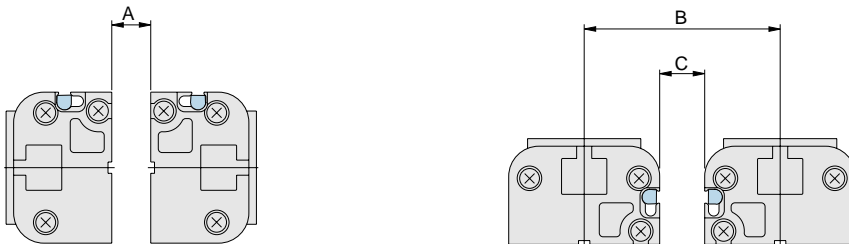

Code	type	Mode						mm
			ORV16	ORV20	ORV25	ORV32	ORV40	ORV50
A	Solid state type		0	0	0	0	0	0
	Reed switch type		0	0	0	0	0	0
B	Solid state type		44	52	61	77	91	111
	Reed switch type		49	58	69	86	102	119
C	Solid state type		4	4	5	7	7	9
	Reed switch type		9	10	13	16	16	17

Instructions for Connecting Reed Type Sensor Switch

2-lead wire type

Basic connection

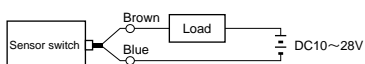

Connection to relay

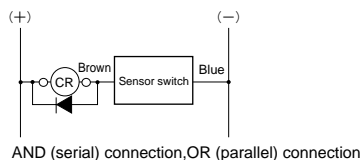

AND (serial) connection, OR (parallel) connection

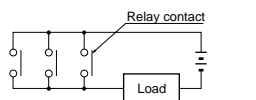
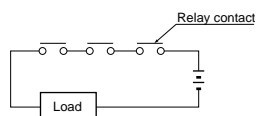
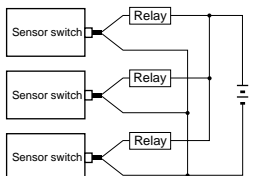

Connection to solenoid valve

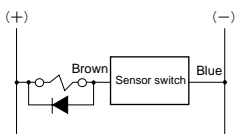

Connection to programmable controller

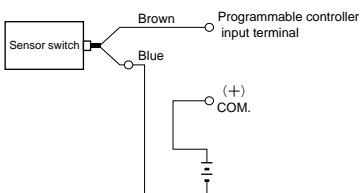

3-lead wire type

Basic connection

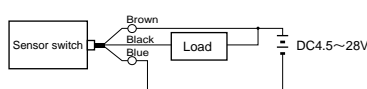

Connection to relay

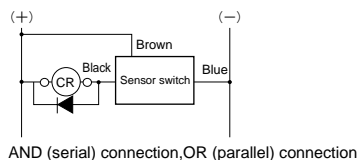

AND (serial) connection, OR (parallel) connection

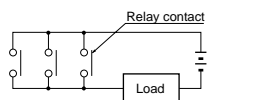
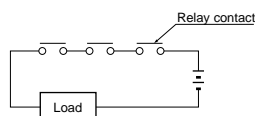
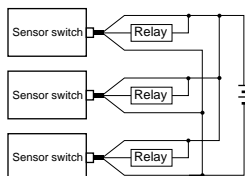

Connection to solenoid valve

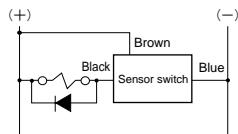

Connection to programmable controller

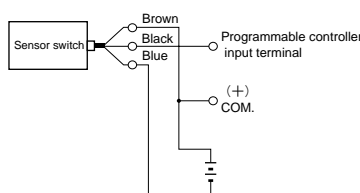

Connection to TTL

Separate connection

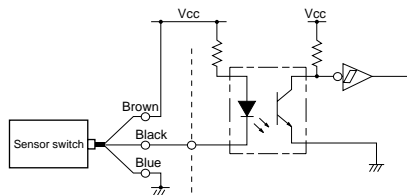

Direct connection

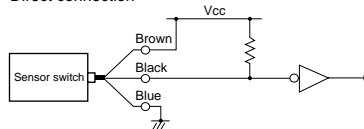

Connection to C-MOS

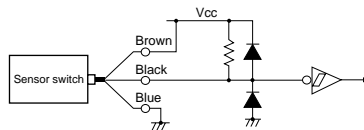

- Caution:**
1. Be careful of the wiring colors for wiring connections. The lack of surge protection means that miswiring could damage the switch.
 2. Do not connect the 2-wire solid state sensor switch to TTL or C-MOS.
 3. We recommend the use of surge protection diodes for the induction loads of solenoid relays, etc.
 4. Since the circuit voltage will drop in proportion to the number of sensor switches, avoid use of AND (serial) connections.
 5. While it is possible to use pairs of sensor outputs (such as pairs of black wires) when using OR (parallel) connections, be aware that leakage voltage will increase by times of the number of sensor switches and may cause load return abnormalities.

6. Since the sensor switch is a magnetically sensitive type, avoid using in locations subject to strong external magnetic fields, or placing it too close to power lines or other large electric flows.
7. Do not pull strongly on the lead wires, bend them too far, or subject them to excessive force.
8. Avoid use in environments subject to chemical products or gases, etc.
9. Consult with us for use in ambient atmospheres subject to water or oil.

Limited Warranty

KOGANEI CORP. warrants its products to be free from defects in material and workmanship subject to the following provisions.

Warranty Period The warranty period is 180 days from the date of delivery.

KOGANEI Responsibility If a defect in material or workmanship is found during the warranty period, KOGANEI will replace free of charge any part proved defective under normal use and will provide the service necessary to service such part.

Limitations

- This warranty is in lieu of all other warranties, expressed or implied, and is limited to the original cost of the product and shall not include any transportation, the cost of installation or any liability for direct, indirect or consequential damages or delay resulting from defects.

- KOGANEI CORP. shall in no way be liable or responsible for injuries or damages to persons or property arising out of the use or operation of the manufacturer's product.

- This warranty shall be void if the engineered safety devices are removed, made inoperative or not periodically checked for proper functioning.

- Any operation beyond the rated capacity, or the improper use, application, or installation of the product, or substitution upon it of parts not furnished or approved by KOGANEI CORP., shall void this warranty.

- This warranty covers only such items supplied by KOGANEI CORP. The products of other manufacturers are covered only by such warranties as made by these original manufacturers, even though such items may have been included as components.

These specifications are subject to change without notice.

URL:<http://www.koganei.co.jp>



KOGANEI

KOGANEI CORPORATION

OVERSEAS DIVISION

Shinjuku-TX Bldg., 1-3-21, Ohkubo Shinjuku-ku, Tokyo 169-0072 Japan
Tel: 03-5272-8781 Fax: 03-5286-2763

LOS ANGELES REPRESENTATIVE OFFICE

3838 Carson street, Suite 329, Torrance, CA 90503 USA
Tel: 310-792-0471 Fax: 310-792-0462

SINGAPORE REPRESENTATIVE OFFICE

Block 1001, Jalan Bukit Merah #06-08 Singapore 159455
Tel: 2736461 Fax: 2752551